

Octopus



COMPACT TSi

- **Integrated Top Sheet Device for Packaging Quality and Space Savings**

Dust or water protection.
Significant space savings on the factory floor and an efficient wrapping process without any stand-by time.

- **Container Compatible for Overseas Deliveries**

- **Easy and Safe Maintenance**

All wrapping unit motors located on the moving unit. Therefore the preventive maintenance work can be done easily and safely from the factory floor level.



- **No Touch No Tail for Automatic Warehouse Compatibility**

No Touch No Tail seaming with durable cutting element leaves no hazardous film tails and prevents the seaming device from touching the load itself

- **OctoFACE HMI for a Visual User Experience**

HALOILA

Machines & Service

www.haloila.com

FULLY AUTOMATIC STRETCH WRAPPING MACHINE WITH INTEGRATED TOP SHEET DISPENSER FOR LOW CAPACITY END OF LINE SOLUTIONS

NEW OCTOPUS COMPACT TSi SERIES

A completely new design with integrated Top Sheet device, based on the proven Octopus design and ring technology.

The Octopus Compact TSi provides optimal load containment while optimizing the film usage. The ring technology means that the wrapping can be done for instance from bottom to top, or vice versa, or just single wrapping, decreasing significantly the film usage.

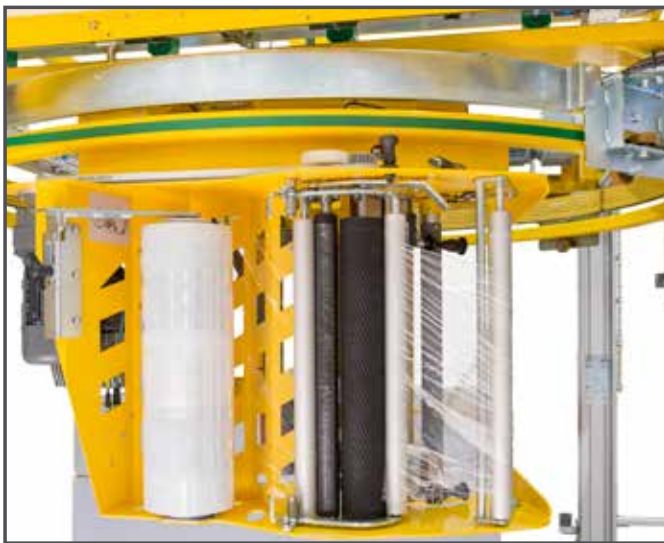

“S” type film carriage for easy, quick and safe film reel change. “S” type film carriage structure offers less film necking and better Pre-Stretch performance compared to W-type film carriage, and significantly lowers the overall cost of ownership.

Octopus Compact TSi is equipped with No Touch No Tail film seaming as standard. No Touch No Tail seaming leaves no hazardous film tails and prevents the seaming device from touching the load itself.



The Integrated Top Sheet Dispenser to protect the load against either dust or water ingress. It gives significant space savings on the factory floor and the top film positioning is extremely accurate. It allows a solid top cover without any film seaming on top of the pallet. The whole wrapping process is fluent and efficient as the top sheet is added during the wrapping cycle.



OctoFACE HMI for a visual user experience, tailored for various demands, being simple and informative, providing shorter down time and problem solving without any technical personnel.

Options

- Load stability improvement by **stretch film roping**
- **Tail Tucker** - cycle end and film cut solution for construction industry.

Technical data of Octopus Compact TSi



Standard configuration listed below.
Please contact your sales representative for additional options.

Air & Power Requirements

Power: 3 x 380 VAC / 50 Hz
3 x 400 VAC / 50 Hz
3 x 415 VAC / 50 Hz

Pneumatics: 0.6 MPa, max 50 l/cycle

Structure

Aluminum frame

Performance

Speed: 20 rpm

Maximum Load Size: 1300 mm W x 1300 mm L x 2000 mm H, optional height 2400 or 2800 mm (conveyor height 500 mm)

Note: Maximum load size depends on the width and length combination. Please contact us for more information.

Minimum Pallet Height: 750 mm with top sheet

Maximum Load Weight: Dependent on conveyor

Shipping Information

Dimensions: 2310 mm W x 3700 mm L x 1450 mm H

Machine Weight: 1500 kg

Film Delivery System

Film Capacity: 500 mm W x 250 mm Dia.

Film Payout: Constant control

Tension Control: Adjustable from HMI

Film Threading: Easy thread "S" carriage

Cut & Seal: No Touch-No Tail (NT²) seamer

Optional Equipment

Pallet lift device
Safety light guarding
Conveyors
Roping device
Tail tucker
Ring maintenance locks
Safety fence with electrical lockout switch

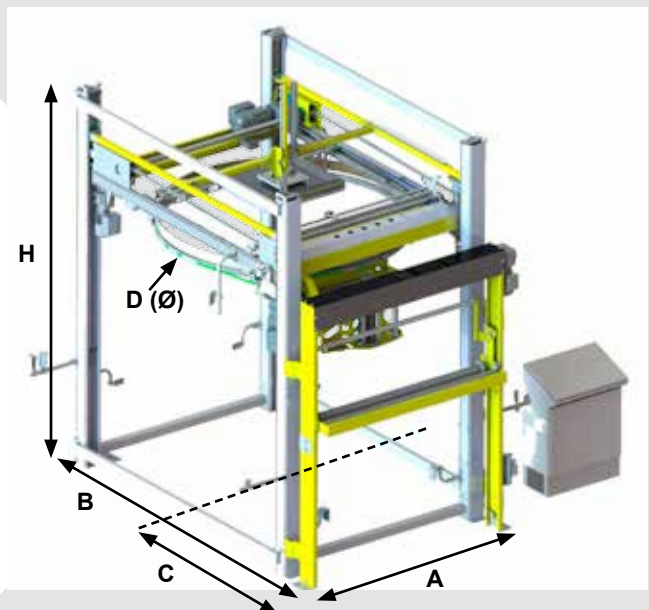

Machine Dimensions

A	B	C	D	H* (frame)
2190 mm	3484 mm	1840 mm	2300 mm	3420 / 3920 / 4420 mm

*Additional height for load stabilizer

630 mm

SIGNODE INDUSTRIAL GROUP

THE PREMIUM PORTFOLIO OF INDUSTRIAL PACKAGING BRANDS
PROVIDING INNOVATIVE SOLUTIONS IN INDUSTRIAL PACKAGING



With over 40 years of history, Haloila Oy is a leading global supplier of automatic stretch wrapping machines and services. More than 6000 Octopus machines have been delivered to over 60 countries.

We are part of Signode Industrial Group which is comprised of over 100 business units located all over the world, that specialize in their unique packaging machinery and packaging materials products.

Signode Industrial Group produces strap, stretch and protective packaging. It also manufactures packaging tools and equipment used to apply the bulk packaging materials. These commercial packaging products are used to contain, unitize, protect and secure goods during warehousing and shipment. Signode Industrial Group is a pioneer in the industrial packaging sector with a long history of customer-focused innovations in materials, processes and automation technology that have revolutionized the sector.

We reserve the right to make technical changes or modify the contents of this document without prior notice.

© Copyright 2017 Haloila All rights reserved.

Specifications subject to change without notice.

